

# Smart Home Automation Security and Energy Efficient Wireless System using GSM

**M. Manasa<sup>1</sup>, M. Vanitha<sup>2</sup>**

M.Tech, PG Student<sup>1</sup>

Assistant Professor<sup>2</sup>

**Abstract:** Home security is becoming necessary nowadays as the possibilities of intrusion are increasing day by day. Safety from theft, and fire are the most important requirements of home security system for people. A traditional home security system gives the signals in terms of alarm. With the help of technology development, this research take a chance to implement these technologies to help people to protect and control their home appliance remotely with advancement of technology things are becoming simpler and easier for us. Automatic systems are being preferred over manual system. This unit talks about the basic definitions needed to understand the Project better and further defines the technical criteria to be implemented as a part of this project. Smart home is a house that uses information technology to monitor the environment, control the electric appliance and communicates with the outer world. Smart home is a complex technology, at the same time it is developing. A smart home automation system has been developed to automatically achieve some activities performed frequently in daily life to obtain more comfortable and easier life environment. Security has becoming an important issue everywhere. The purpose of this research is to create a system that makes the surveillance of home devices easily. The technology that used in this research are GSM (Global System for digital mobile telecommunication ) and Microcontroller .The GSM module is used to communicate with the owner of the home whenever the sensor senses a fault , a specific message is sent to the owner in order to take a necessary action . The microcontroller is a tool that uses a specific code to do some functions by using MicroC programmer.

**Keywords:** Smart Home Automation Security, Energy Efficient, GSM, Wireless System.

## I. INTRODUCTION

With advancement of technology things are becoming simpler and easier for us. Automation is the use of control systems and information technologies to reduce the need for human work in the production of goods and services. In the scope of industrialization, automation is a step beyond mechanization. Whereas mechanization provided human operators with machinery to assist them with the muscular requirements of work, automation greatly decreases the need for human sensory and mental requirements as well.

Automation plays an increasingly important role in the world economy and in daily experience. Automatic systems are being preferred over manual system. Through this project we have tried to show automatic control of a house as a result of which power is saved to some extent.

## II. HOME AUTOMATION

Home/office automation is the control of any or all electrical devices in our home or office, whether we are there or away. Home/office automation is one of the most exciting developments in technology for the home that has come along in decades. There are hundreds of products available today that allow us control over the devices automatically, either by remote control; or even by voice command.

Home automation (also called domotics) is the residential extension of "building automation". It is automation of the

home, housework or household activity. Home automation may include centralized control of lighting, HVAC (heating, ventilation and air conditioning), appliances, and other systems, to provide improved convenience, comfort, energy efficiency and security. Disabled can provide increased quality of life for persons who might otherwise require caregivers or institutional care.

A home automation system integrates electrical devices in a house with each other. The techniques employed in home automation include those in building automation as well as the control of domestic activities, such as home entertainment systems, houseplant and yard watering, pet feeding, changing the ambiance "scenes" for different events (such as dinners or parties), and the use of domestic robots. Devices may be connected through a computer network to allow control by a personal computer, and may allow remote access from the internet.

Typically, a new home is outfitted for home automation during construction, due to the accessibility of the walls, outlets, and storage rooms, and the ability to make design changes specifically to accommodate certain technologies. Wireless systems are commonly installed when outfitting a preexisting house, as they reduce wiring changes. These communicate through the existing power wiring, radio, or infrared signals with a central controller. Network sockets may be installed in every room like AC power receptacles. Although automated homes of the future have been staple exhibits for World's Fairs and popular backgrounds in

science fiction, complexity, competition between vendors, multiple incompatible standards and the resulting expense have limited the penetration of home automation to homes of the wealthy or ambitious hobbyists.

### III. NEED OF AUTOMATION

Earlier, we looked into the face of future when we talked about automated devices, which could do anything on instigation of a controller, but today it has become a reality.

a) An automated device can replace good amount of human working force, moreover humans are more prone to errors and in intensive conditions the probability of error increases whereas, an automated device can work with diligence, versatility and with almost zero error. Replacing human operators in tasks that involve hard physical or monotonous work. Replacing humans in tasks done in dangerous environments (i.e. fire, space, volcanoes, nuclear facilities, underwater, etc)

Performing tasks that are beyond human capabilities of size, weight, speed, endurance, etc.

Economy improvement. Automation may improve in economy of enterprises, society or most of humankind. For example, when an enterprise that has invested in automation technology recovers its investment, or when a state or country increases its income due to automation like Germany or Japan in the 20th Century.

b) This is why this project looks into construction and implementation of a system involving hardware to control a variety of electrical and electronics system.

### IV. SMART HOME WITH SECURITY

There are many sensors we have used in this system (like temperature sensor, motion sensor, etc). In order to make home energy efficient we also paid attention on home devices like fans and lights .Moreover , the system also focus on outside environment such as main door , garage door and irrigation. The heart of this system is a PIC18F452 microcontroller which is controlling home devices. If the thermometer feels an increase in room temperature then an electrical signal is sent to microcontroller, the microcontroller takes a necessary action like turn the fan on which work as air-conditioning.

In case, there is a smoke in home smoke sensor detects the smoke then send a signal to microcontroller to turn the extractor on, to take out the smoke from home. In case, the owner away from home he turns the motion sensor on. In order to detect the motion inside home while he away from home. If it detects a motion then send a signal to the microcontroller and microcontroller send a specific SMS message to the owner through GSM module. In order to take a necessary action like call the police station. Protection of home door is the important part in security system which is done in this system by using electromagnetic lock, LCD and keypad.

The owner using keypad to enter the password which is displayed in LCD and if the password entered is correct then the electromagnetic lock is opened. Otherwise the password entered is wrong, the door will still locked .There are two ways of control for garage door which are wireless and manual. The first, wireless control is done by using GSM module technology that allow the owner to send a SMS message to GSM module then GSM module send a signal to microcontroller to open the garage door . The second, manual control which means there is a switch near garage door to open and close the door. The garden of house is the place where most people stay at rest time. This system including irrigation system for the garden, in order to take care of house garden. The irrigation is done by using pump which operates on timer.

### V. HARDWARE DESIGN AND DEVELOPMENT

#### V.I Block Diagram

Figure 1 illustrates a block diagram of the planned smart home and security system design with its hardware components involved and connections. The main components are: Microcontroller (PIC 18F452), GSM, Keypad, LCD, LM293 driver, Door locker, and power supply.

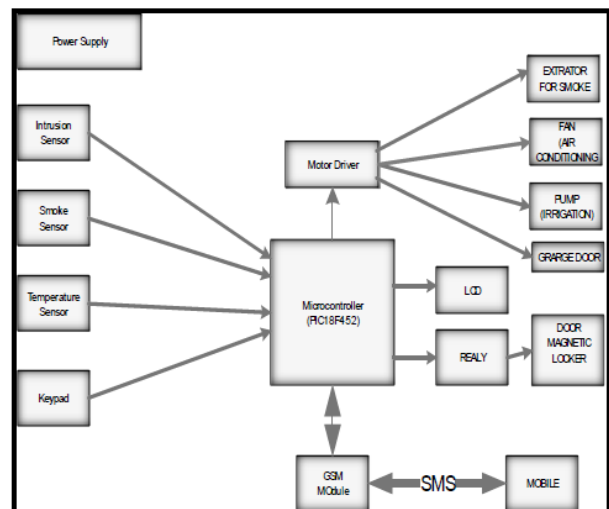

Fig-1: Block Diagram of the Proposed System

#### Microcontroller AT89S52

The microcontroller AT89S52 is a low power, high-performance CMOS 8-bit microcontroller with a 8k byte of in-system programmable flash memory. The ATMEL AT89S52 is a powerful microcontroller which provides a highly-flexible and cost-effective solution to many embedded controller application, it has 256 x 8-bit internal ram and having 8 interrupt sources with three 16-bit timer/counters. This is compatible with MCS-51 products, 8k byte of in-system programmable (ISP) flash memory

#### GSM

In the GSM we have selected a particular “SIMENS GSM MODEM” in this project. The messages are sent from the mobile set to that contain commands in written form

which are then processed accordingly to perform the required task. A microcontroller based system has been proposed for our project. There are several technologies that are used extensively throughout this project report. The main concept behind this project is that to receive the sent SMS and processing it further as required to perform several operations. The type of operation to be performed depends on the nature of SMS sent.

**Interfacing LCD to 89S52**

Now a day electronic project without LCD looks incomplete. Interfacing with Atmel microcontroller is very task. You just have to know the proper LCD programming algorithm. LCD used here has HD44780u dot matrix LCD controller. LCD modules have 8-bit data interface and control pins. One can send data an 8-bit or in pair of two 4-bit nibbles. To display any character on LCD microcontroller has to send its ASCII values to the data bus of LCD for e.g. to display „AB“ microcontroller has to send two hex bytes 41h and 42h respectively. LCD display used here is having 16x2 sizes. It means 2lines each with 16characters

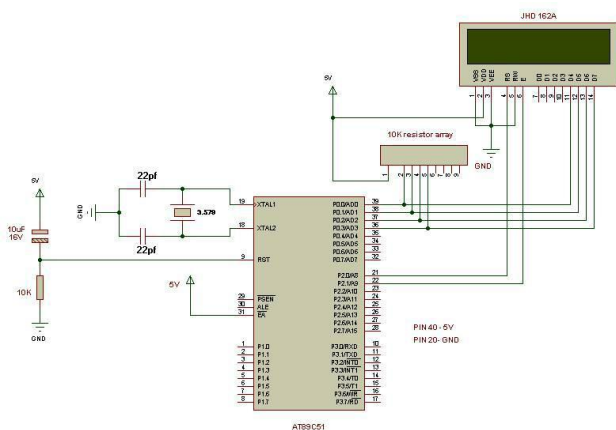

**Figure 2: Schematic design of interfacing LCD to 89S52**

**LCD Initialization**

This is the pit fall for beginners. Proper working of LCD depend on the how the LCD is initialized. We have to send few commands bytes to initialize the LCD. Liquid crystal display is also called as LCD is helpful in providing user interface as well as for debugging purpose. The most common type of LCD controller is HITACHI 4478 which provides a simple interface between the controllers as well as are cost effective.



**Figure 3: LCD Display**

**Relay Introduction**

The first relay was invented by Joseph Henry in 1835. The name relay derives from the French noun relays that indicate the horse exchange place of the postman. Generally a relay is an electrical hardware device having an input and output gate. The output gate consist in one or more electrical contacts that switch when the input gate is power, a negation, and on the base of the past relays had wide use, for instance the telephone switching the railway routing and crossing system. Relays are usually SPDT or DPDT but they can have many more sets of switch contacts.

**VI. WORKING PROCEDURE**

The objective of this project is to develop a device that allows for a user to remotely control and monitor multiple home /office appliances using a cellular phone. This system will be a powerful and flexible tool that will offer this service at any time, and from anywhere with the constraints of the technologies being applied. The application of our system comes into handy when people who forget to do simple things such as turn ON/OFF devices at their home or in their office they can now do so without their presence by the transmission of a simple text message from their mobile phone.

This development, we believe, will ultimately save a lot of time especially when people don't have to come back for simple things such as to turn ON/OFF switches at home or at their office once they set out for their respective work. How we have implemented our project and the various parts involved in it, from the above representation the first mobile station is used as a transmitting section from which the subscriber sends a text message that contain command and instructions to the second mobile station which is based on a specific area where our control system is located.

The mobile phone indicated in the block diagram is a Siemens GSM modem set. The received SMS message is stored in the SIM memory of the phone and then extracted by the microcontroller and processed accordingly to carry out specific operations. The LCD is used to indicate the status of the operation performed by the microcontroller and also its inclusion makes the overall system user-friendly. GSM receiver receives message sent from the user call phone, microcontroller issues commands to the appliances and the devices connected will switch ON/OFF.

**VII. RESULT**

The project GSM based home automation with security using a microcontroller designed a complete remote handling. From owner GSM mobile sending a message to the GSM modem located in the home or office is considered to be as an input and the respective action performed by the microcontroller by switching ON or OFF the relays is considered to be the output.

### VIII. CONCLUSION

Our project goal was to implement a smart home system by controlling the electronic devices at home remotely with a mobile phone and to receive alerts on intrusion and movement around restricted place. The goal was achieved successfully. The devices were controlled by sending instructions as an SMS and the alerts were received as an SMS as well. A passive infrared sensor was used as detectors to detect the intrusion and movement around the restricted premises respectively.

A temperature sensor was used as a heat detector and a led light was used to show the demonstration of an electronic device management. SIM900 GSM module was interfaced with PIC18F452 microcontroller properly. The SIM900 GSM module was used for communication between the microcontroller unit and the mobile station. The mobile phone did not need to have any special application or hardware to be used as a mobile station. Any mobile phone supporting the SMS could be used as a mobile station. The developed GSM based security system gives good response to the sensor and sends SMS when it detects the fire or temperature is increased above desired level. As well, it can send a message to the user for action when the owner is out of station and the home is locked which helps us to keep more secure of our home. Moreover, owner can control loads (on/off) automatically by mobile using GSM technology from anywhere. Flexibility with the technical customization and economy are the main advantages of the design. This project will have a large effect to the living standard of human being. In the system, a lot of other features can be added to the user's requirement depending upon the situation.

[10]. [http://www.rhydolabz.com/documents/gps\\_gsm/si900\\_rs232\\_gsm\\_modem\\_opn.pdf](http://www.rhydolabz.com/documents/gps_gsm/si900_rs232_gsm_modem_opn.pdf)

### REFERENCES

- [1]. E Wong "A Phone-Based Remote Controller for Home and Office Automation", IEEE Trans Consumer Electron, vol.40, No. 1, pp. 28- 33, 1995.
- [2]. J. Burroughs, "X-10 home automation using the PIC16F877A," Lamp, vol. 10, article 10, 2010. [3]. A. Z. Alkar, and U. Buhur, "An Internet Based Wireless Home Automation System for Multifunctional Devices, "IEEE Transactions on Consumer Electronics, vol. 51, no.4, pp. 1169-1174, 2005.
- [4]. Piyare, R., Tazil M., "Bluetooth based Home Automation System using Cell Phone", IEEE 15th International Symposium on Consumer Electronics, pp. 192-195, 2011.
- [5]. Jayashri Bangali and Arvind Shaligram" Design and Implementation of Security Systems for Smart Home based on GSM technology", International Journal of Smart Home Vol.7, No.6 (2013), pp.201-208.
- [6]. Yuksekkaya, B., Kayalar, A.A., Tosun, M.B., Ozcan, M.K., Alkar, A.Z., "A GSM, Internet and Speech Controlled Wireless Interactive Home Automation System", IEEE Transactions Consumer Electronics, vol. 52, no. 3, pp. 837-843, 2006.
- [7]. Y. Zhao and Z. Ye, "A Low Cost GSM/GPRS Based Wireless Home Security System", IEEE Transactions on Consumer Electronics, vol. 54, no. 2, pp. 567-572, 2008.
- [8]. GSM Based Home Automation with Security (Using Microcontroller) Dr. Shaik Meeravali 1, P. Sai Prasad 2 International Journal of Engineering Research &Technology (IJERT) Vol. 2 Issue 9, September -2013ISSN: 2278-0181.
- [9] [http://www.microchip.com/wwwproducts/Device\\_s.aspx?product=PIC18F452](http://www.microchip.com/wwwproducts/Device_s.aspx?product=PIC18F452)